



Fenner® Tensioners

Standard, Stainless Steel, Front Mounted and Boomerang Chain Tensioners

The Fenner® chain tensioners are a simple to use accessory that helps to achieve optimum drive performance, maintain correct chain drive tension and reduce vibration frequency of the chain drive.

Benefits

- > Increase chain life
- > Noise and vibration damping
- > Absorbs shock loads
- > Maintenance free
- > Safe in operation
- > Self adjusting
- > Progressive spring characteristics
- > Operating angle -30° to +30°
- > Ambient operating resistant to temperature -40°C to +80°C



Size Reference

Standard - (STB) F2 to F8
 Stainless steel - (STBSS) FT4 to FT6
 Front mounted - (FMTB) FT3 to FT8
 Boomerang - (STBB) FT4 to FT6

Construction

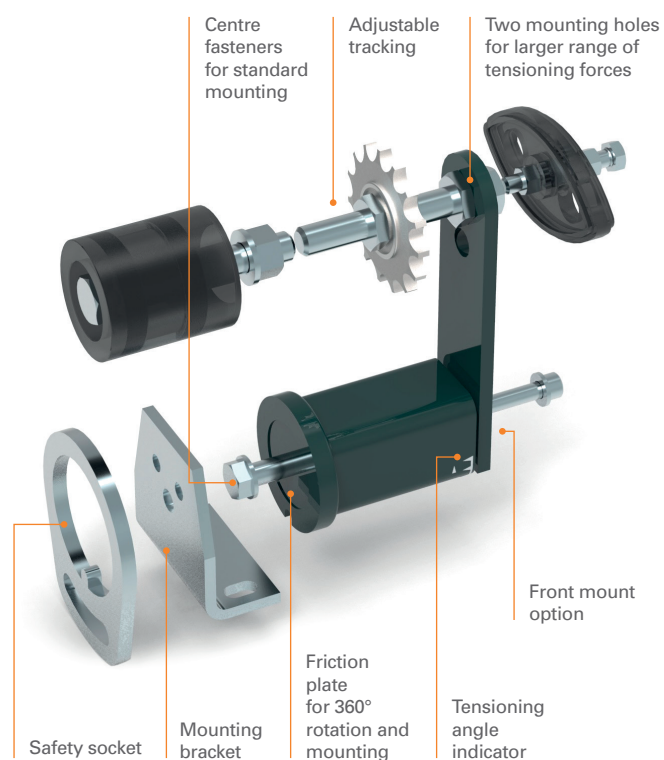

Fenner®

Reliable | Trusted | Connected